



RAIL TARIFF

This Rail Tariff is an integral part of intermodal transport arrangement – service provided by PCC Intermodal S.A. and therefore it cannot be used as a standalone offer, only in combination with to-door delivery service regulated by Trucking Tariff. PCC Intermodal S.A. operate on the basis of the valid General Terms of Intermodal Transport Arrangement („GTITA”). GTITA and complete tariff are available at the company official website <http://www.pccintermodal.pl/en/about-company/for-download/>
Please read GTITA before sending an order to PCC Intermodal S.A.

THE RAIL RATES

CURRENCY = PLN		OneWay			RoundTrip		
		20`	30`	40`	20`	30`	40`
SOUTHBOUND	NORTHBOUND						
Gdynia/Gdańsk – Kutno	Kutno – Gdynia/Gdańsk	700	850	1000	1000	1250	1500
Gdynia/Gdańsk – Brzeg Dolny	Brzeg Dolny – Gdynia/Gdańsk	950	1200	1450	1450	1800	2150
Gdynia/Gdańsk – Gliwice	Gliwice – Gdynia/Gdańsk	950	1200	1450	1450	1800	2150
Gdynia/Gdańsk – Kolbuszowa	Kolbuszowa – Gdynia/Gdańsk	1000	1250	1500	1500	1850	2200
Gdynia/ Gdańsk – Poznań	Poznań – Gdynia/ Gdańsk	1000	1250	1500	1500	1850	2200
Gdynia/Gdańsk – Brest	Brest – Gdynia/Gdańsk	2000	2385	2500	2800	3250	3800

CURRENCY = PLN	OneWay		
	20`	30`	40-45`

POSITIONING OF EMPTY CONTAINERS BETWEEN PCC INTERMODAL TERMINALS

Gliwice – Brzeg Dolny	Brzeg Dolny – Gliwice	500	600	700
Brzeg Dolny/ Gliwice/ Kolbuszowa – Kutno	Kutno – Brzeg Dolny/ Gliwice/ Kolbuszowa	500	600	700
Gliwice – Kolbuszowa	Kolbuszowa – Gliwice	600	700	800
Brzeg Dolny – Kolbuszowa	Kolbuszowa – Brzeg Dolny	600	700	800



CURRENCY = EURO		OneWay			RoundTrip		
WESTBOUND	EASTBOUND	20'	30'	40'-45'	20'	30'	40'-45'
Frankfurt Oder – Rotterdam	Rotterdam – Frankfurt Oder	300	450	600	500	750	1 000
Kutno – Rotterdam	Rotterdam – Kutno	500	650	800	800	1 050	1 400
Brzeg Dolny – Rotterdam	Rotterdam – Brzeg Dolny	475	625	775	750	1 050	1 350
Gliwice – Rotterdam	Rotterdam – Gliwice	500	650	800	800	1 050	1400
Kolbuszowa – Rotterdam	Rotterdam –Kolbuszowa	600	800	1 000	1 000	1 400	1 800
Poznań – Rotterdam	Rotterdam – Poznań	400	550	700	650	925	1200
Brest – Rotterdam	Rotterdam – Brest	750	1 050	1 350	1 375	1 825	2 250
<hr/>							
Frankfurt Oder – Antwerp	Antwerp – Frankfurt Oder	400	600	800	600	900	1 200
Kutno – Antwerp	Antwerp – Kutno	600	800	1000	900	1 200	1 600
Brzeg Dolny – Antwerp	Antwerp – Brzeg Dolny	575	725	975	850	1 200	1 550
Gliwice – Antwerp	Antwerp – Gliwice	600	800	1000	900	1 200	1600
Kolbuszowa – Antwerp	Antwerp – Kolbuszowa	700	950	1 200	1 100	1 550	2000
Poznań – Antwerp	Antwerp – Poznań	500	700	900	750	1075	1400
Brest – Antwerp	Antwerp – Brest	850	1 200	1 550	1 475	1 975	2 450
<hr/>							
Frankfurt Oder – Duisburg	Duisburg – Frankfurt Oder	n/a	n/a	n/a	n/a	n/a	n/a
Kutno – Duisburg	Duisburg – Kutno	460	600	740	750	1 000	1 350
Brzeg Dolny – Duisburg	Duisburg – Brzeg Dolny	435	575	715	725	975	1 325
Gliwice – Duisburg	Duisburg – Gliwice	460	600	740	750	1 000	1 350
Kolbuszowa – Duisburg	Duisburg – Kolbuszowa	560	750	940	950	1 350	1 750
Poznań – Duisburg	Duisburg – Poznań	360	500	640	650	900	1250
Brest – Duisburg	Duisburg – Brest	710	1000	1290	1 350	1 775	2 200
<hr/>							
Frankfurt Oder – Hamburg	Hamburg – Frankfurt Oder	200	300	400	300	450	575
Kutno – Hamburg	Hamburg – Kutno	325	450	575	550	750	950
Brzeg Dolny – Hamburg	Hamburg – Brzeg Dolny	325	450	575	550	750	950
Gliwice – Hamburg	Hamburg – Gliwice	350	500	650	575	800	1 025
Kolbuszowa – Hamburg	Hamburg – Kolbuszowa	450	625	800	675	925	1 175
Poznań – Hamburg	Hamburg – Poznań	250	375	500	450	575	700
Brest – Hamburg	Hamburg – Brest	675	925	1 150	1 225	1 575	1 900
<hr/>							
Kutno – Frankfurt	Frankfurt – Kutno	150	200	250	250	325	400

WEIGHT REMARKS

When calculating the rate for 20` containers, with total brutto weight exceeding 22 tones, use 30` rates.

When calculating the rate for 20` / 30` containers, with total brutto weight exceeding 30 tones, use 40` rates.

GENERAL REMARK

THESE ARE THE RAIL RATES ONLY – HANDLINGS ARE NOT INCLUDED!



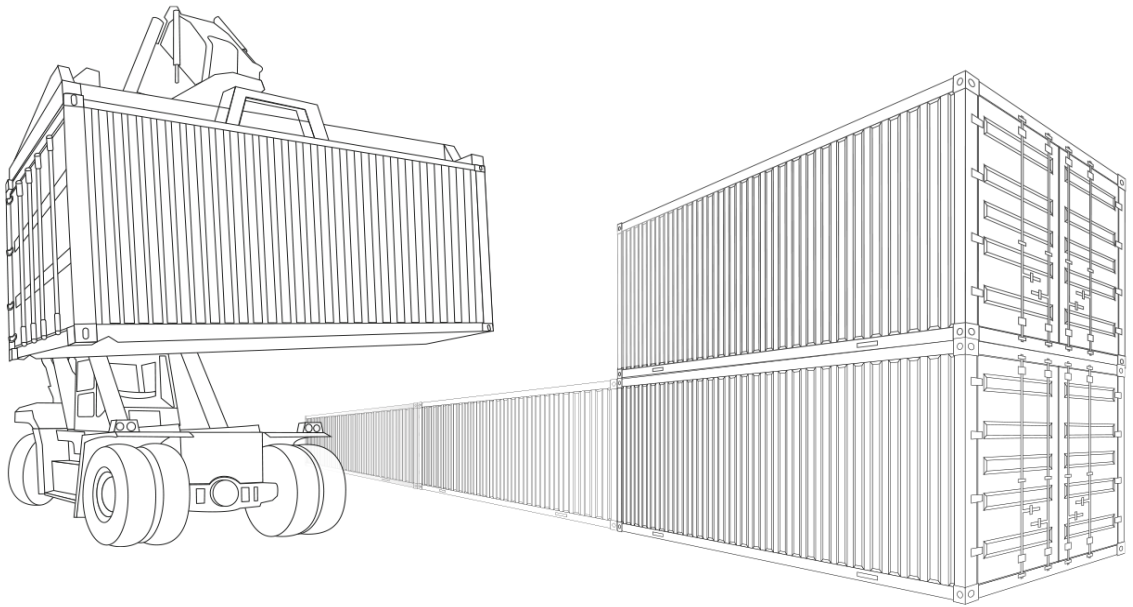

TERMINAL **TARIFF**

PCC Intermodal S.A. operate on the basis of the valid General Terms of Intermodal Transport Arrangement („GTITA”). GTITA and complete tariff are available at the website <http://www.pccintermodal.pl/en/about-company/for-download/> Please read GTITA before sending an order to PCC Intermodal S.A.

PCC Intermodal S.A. TERMINALS OPENING HOURS

Nr	TERMINAL	OPENING HOURS	
1.	GLIWICE	Monday - Friday	06:00 - 22:00
2.	KUTNO		Saturday
3.	BRZEG DOLNY		
4.	LD KOLBUSZOWA	Monday - Friday	06:00 - 22:00
5.	FRANKFURT ODER		

Sundays and national holidays – closed

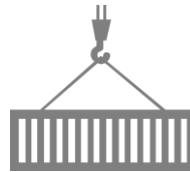

PCC Kutno Terminal
Intermodalna 5
99-300 Kutno

PCC Brzeg Dolny Terminal
Sienkiewicza 6
56-120 Brzeg Dolny

PCC Gliwice Terminal
Portowa 28
44-100 Gliwice

PCC Loading Depot Kolbuszowa
Ks Ludwika Ruczki 3C
36-100 Kolbuszowa

PCC Frankfurt (Oder) Terminal
Georg-Richter-Str. 15
15234 Frankfurt Oder

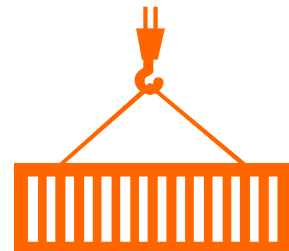

TERMINAL SERVICES AND OPERATIONS¹

	20'		40'/45'	
	EMPTY	FULL	EMPTY	FULL
HANDLINGS				
Container handling^a	22 €			
Semi-trailer/swap body handling^a	44 €			
Manipulation and transshipment^b (additional handlings connected with transshipment within the terminal for service requirements, container repairs, washing, use of emergency tub, handling between the trains etc.)	33 €			
STORAGE²		AVAILABLE FOR NEUTRAL CARGO ONLY!		
Free storage:	TIME FREE OF STORAGE			
containers	7 days	3 days	7 days	3 days
semi-trailers/ swap bodies	24 h			
STORAGE RATES		COST PER DAY AFTER FREE PERIOD^c		
containers^d	8 - 14 days 3 €	4 - 7 days 5 €	8 - 14 days 5 €	4 - 7 days 10 €
	15 - 21 days 5 €	8 - 12 days 7 €	15 - 21 days 10 €	8 - 12 days 15 €
	from 22 days 7 €	from 13 days 10 €	from 22 days 15 €	from 13 days 20 €
semi-trailers/ swap bodies	each next 24 h (once started) 50 €			
OTHER SERVICES				
Sweeping out	15 €	–	20 €	–
Removal of lashing materials	17 €	–	25 €	–
Use of the emergency tub^e	–	100 €	–	100 €
Electrical cooling / heating				
plug in and out	refrigerated	15 €	tank	15 €
power supply and monitoring (per 1h)	containers	3 €	containers	9 €
Removing labels	25 € per container			
Labelling containers (4 IMO labels included in the rate)	25 € per container			
Sealing a container (seal HS)	7 €			
Flexi tank fitting^f	100 €	–	–	–
Flexi tank removal and neutralization^g	150 €	–	–	–
Washing container with water^h	37 €		62 €	
Washing container with detergent^h	50 €		75 €	
Printing or scanning transport documentation	per each 10 pages once started		12 €	

- a. rate includes relocating containers to the depo / semi-trailers to the parking space;
- b. transshipment rate is applicable for direct train-train reloading or when time period between commencement of the terminal slot for train A and end of the terminal slot of train B do not exceed 24 hours;
- c. the rate per day of usage; it does not include the cost of handling and neutralization of pollutants;
- d. for containers bigger than 20' (like: 22, 24 etc.) please use 40' container rate. The rate is valid also for 45' containers. If unloading to yard is before 12.00 the unloading day is calculated as a first storage day. In case unloading is proceeded after 12.00, first day of storage is calculated as from 00:00.
- e. calendar days, including the date of drop off / pick up the container; for the clients using PCCI services
- f. only fitting, without flexi tank and additional materials;
- g. service available only in: Brzeg Dolny and Gliwice; includes removing and neutralization of flexi tank with the leftovers up to 100 kg
- h. service is not available in LD Kolbuszowa; the rate does not include handlings; refers to a single wash; not possible in autumn/winter season;

¹ Any other services not mentioned in the tariff, if are possible to be served by the Terminal can be secured/proceeded only with the separate contract signed ahead.

² Storage services are available only when receiving the Operator confirmation first and signing separate contract, which is specifying detailed conditions and limitations. Storage services exclude warehousing and storage of the hazardous goods. UTI with IMO can be only accepted on the terminal when changing the transport mode is needed for transshipment operations during the transportation proces. The total storage time for transported IMO can not exceed 24h as from the time UTI was accepted to the terminal, excluding aproved emergency situations.

All the charges detailed in the Tariff are net charges (do not include VAT) ! and are valid also for train operators after signing the contract.



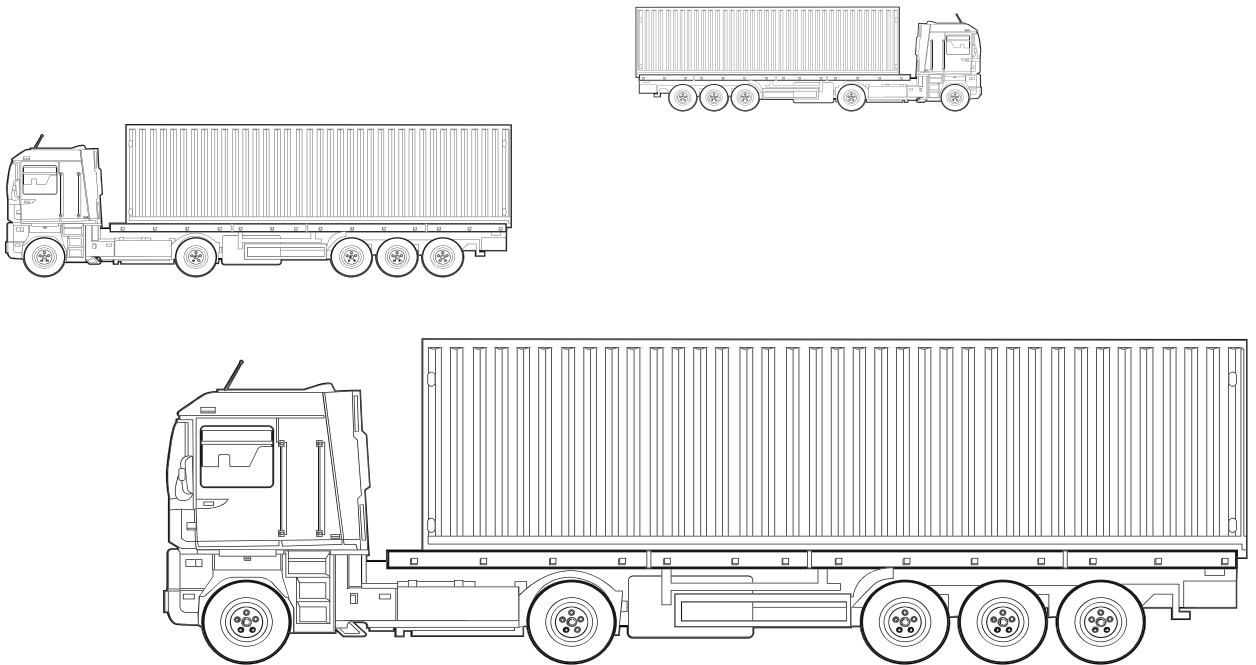

TRUCKING **TARIFF**

This Trucking tariff is an integral part of intermodal service provided by PCC Intermodal S.A. and therefore cannot be used as a standalone offer, only in combination with rail transport service regulated by Rail Tariff. PCC Intermodal S.A. operate on the basis of the valid General Terms of Intermodal Transport Arrangement („GTITA”). GTITA and complete tariff are available at the website <http://www.pccintermodal.pl/en/about-company/for-download/>
Please read GTITA before sending an order to PCC Intermodal S.A.

TRUCKING RATES

rate per km in roundtrip ^{a, b}	4,50 PLN
minimum charge applies	600,00 PLN
1st overweight charge: 20` 40` 45` 22-24t of cargo weight	plus 20%
2nd overweight charge: 20` 40` 45` 22-25t of cargo weight (over 25t of cargo weight – on demand)	plus 30%
for dangerous goods	plus 30%
1 on-truck or 1 off-truck handling	90,00 PLN

- a) The rate include: 2 hours for loading/ unloading operations – if customs procedures not needed.
For customs office procedures and loading/ unloading operations 4 waiting hours included.
- b) Rate of 50 €,- per each comenced hour thereafter will be charged.
- c) Above rate is an aproximate. Pls validate with Sales Department before placing order.

- subject to all "infrastructure" charges, such as: road fees, viatoll, etc.
- a/m are net rates
- rates do not include handlings
- tank containers trucking rates - on request, please contact Sales Department: sales.intermodal@pcc.eu

Truck tariff concerns door deliveries in PCC Intermodal S.A. terminals and depot area.

